

TRANSPORTATION

HOUSING

FOOD

ENERGY



TRANSPORTATION

HOUSING

FOOD

ENERGY

## OUR GUIDING PRINCIPLES



Intensification



Equity



Resilience



Connection

T

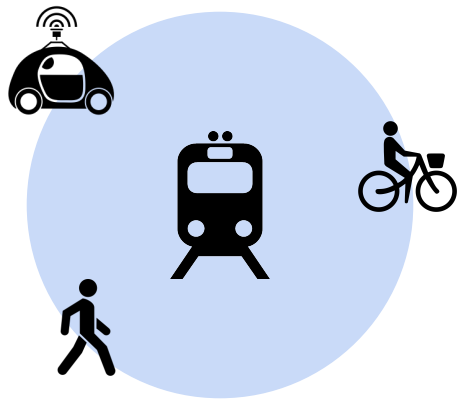

## A Quadrillion Times More Advanced

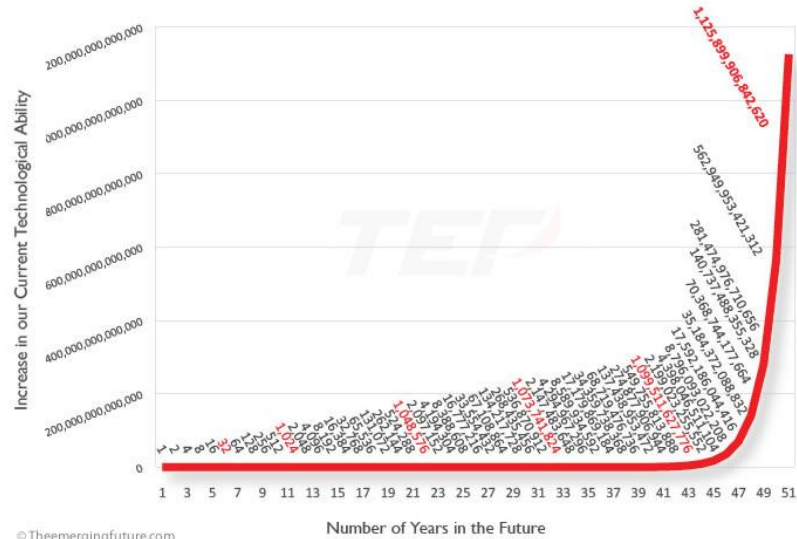



T

# THE EMERGENCE OF NEW PUBLIC AND PRIVATE TRANSPORTATION SOLUTIONS



**Monorail** Photo credit: <http://www.thestar.com>



**Sky tram** Photo credit: <http://www.commons.wikimedia.org>



**Light train** Photo credit: <http://www.commons.wikimedia.org>

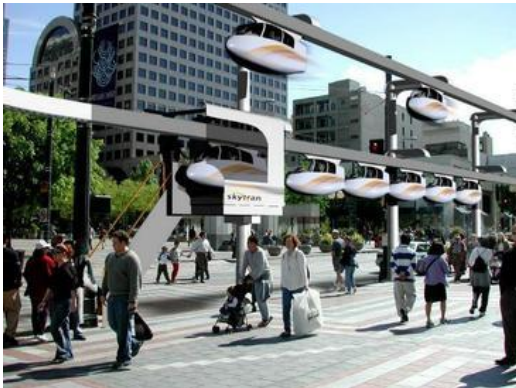

**Sky pods** Photo credit: <http://www.wikipedia.org>



**Autonomous cars** Photo credit: <http://www.documentarytube.com>



**Lima sky pods** Photo credit: <http://www.gondolaproject.com>

T

A LIGHT, HOP-IN HOP-OUT RAILWAY NETWORK IS THE BACKBONE OF OUR COMMUNITY

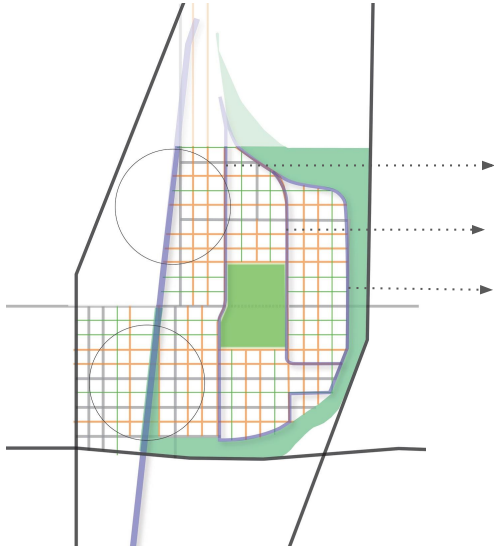



T

## SOCIAL INTEGRATION OF THE TRANSIT INFRASTRUCTURE

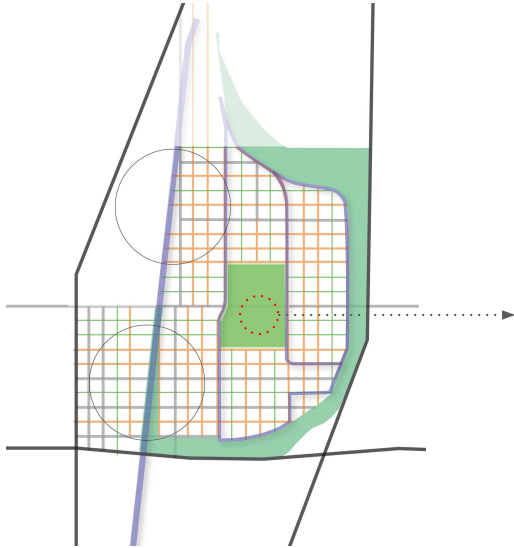

Portland State University - A LRT train goes through the campus every 10 minutes Photo credit: <http://www.walkermacy.com>

T

# COMPLETE STREETS - HEAVY VEHICULAR MOVEMENT

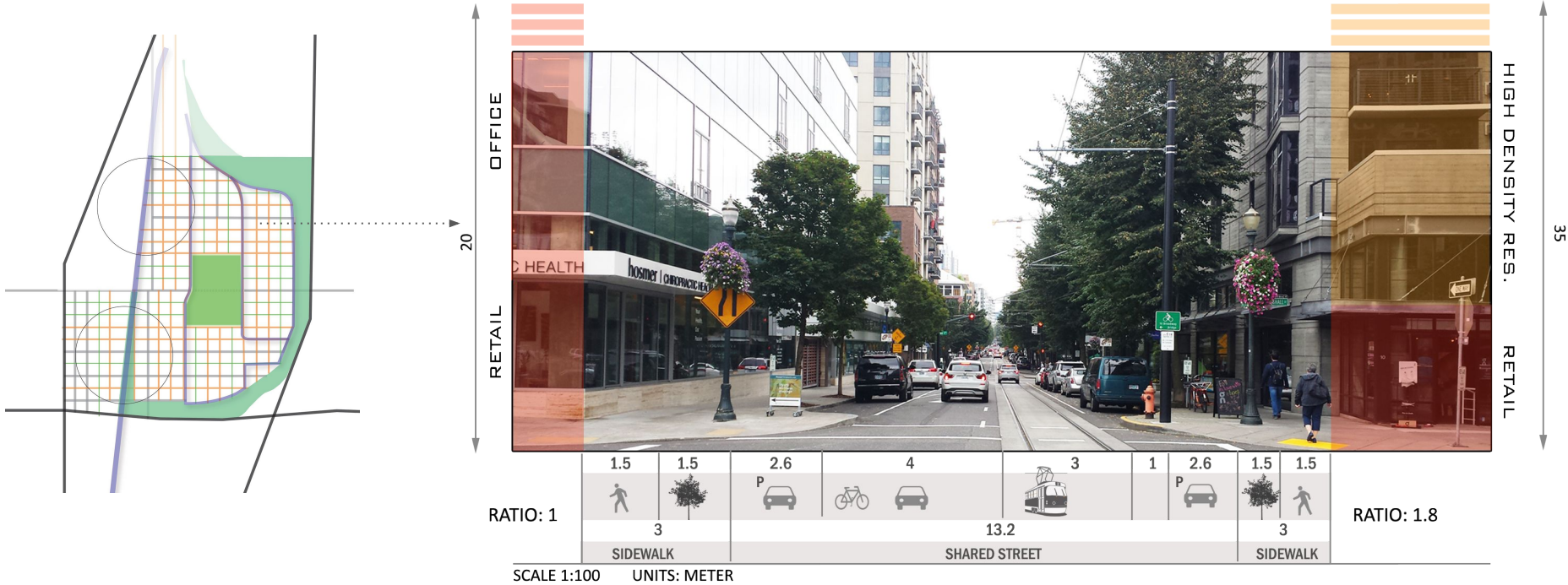

Typical complete street in Portland, Pearl District



T

## SHARED STREETS - BECOME THE NORM

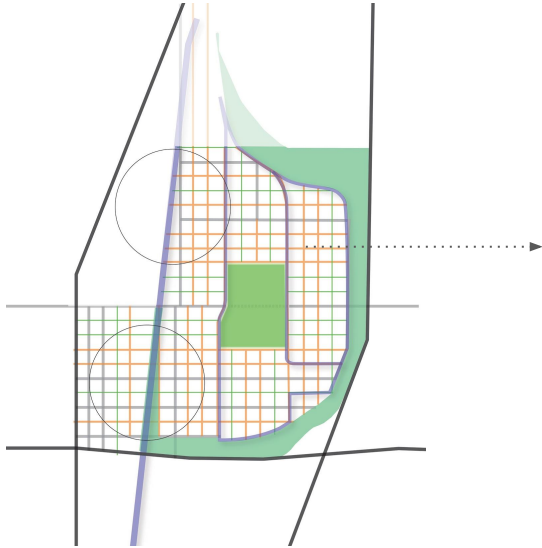
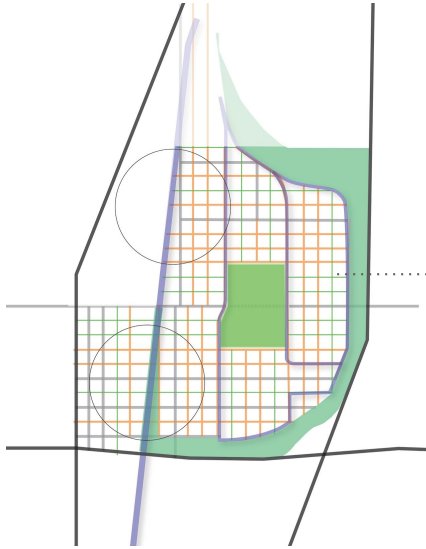

Photo credit: <http://www.landezine.com>

T

# A WIDE NETWORK OF PEDESTRIAN TRAILS SERVICES THE ENTIRE NEIGHBORHOOD



Pedestrian street in Québec City

Photo credit: <http://www.mahanrykiel.com>



Pedestrian Trail network in Portland, Or



T

THE CORE OF MANCHESTER 2060 IS ENTIRELY CAR FREE

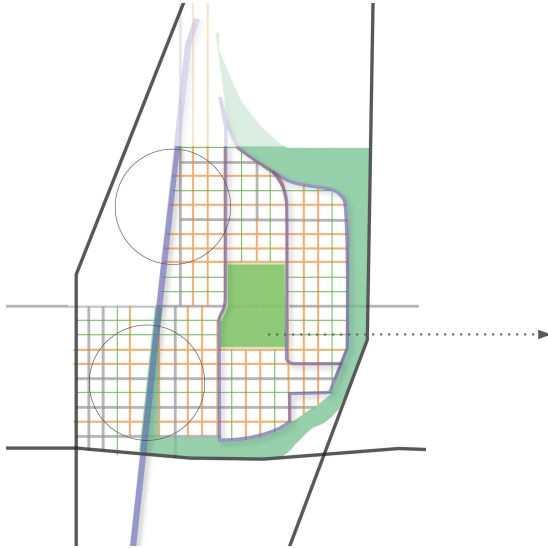

## ROAD NETWORK HIERARCHY

ARTERIAL STREETS

COMPLETE STREETS

SHARED STREETS

PEDESTRIAN TRAILS

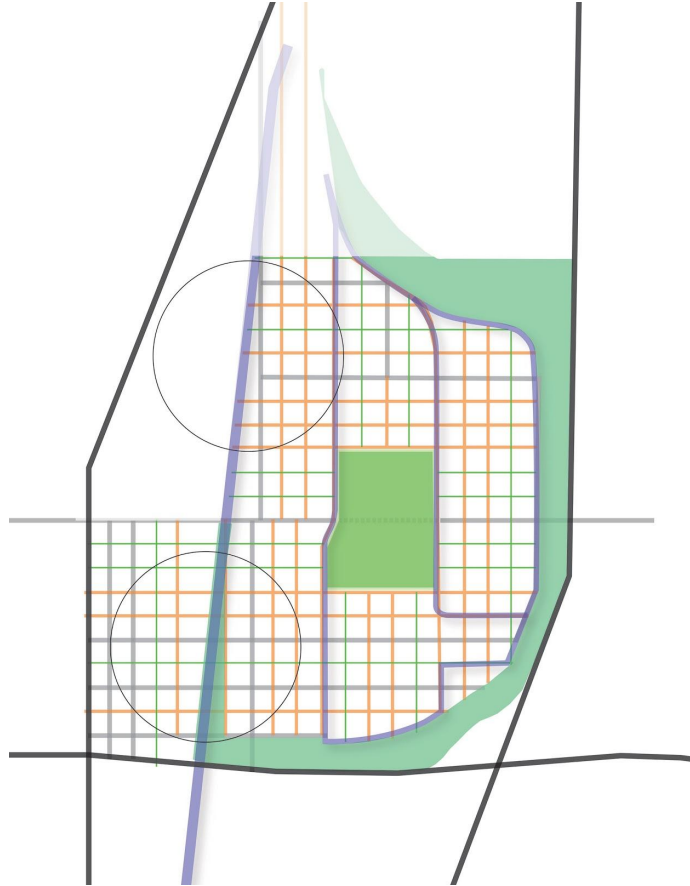

## TRANSPORTATION SHARE

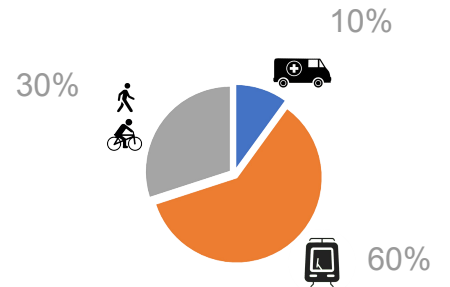



T

## SUPPORTING SOLUTIONS



Compact parking tower Photo credit: <http://www.jalopnik.com>



Integrated parking Photo credit: <http://www.youtube.com>

H



H

# HOW DO WE HOUSE 50,000 PEOPLE IN 440 ACRES?

## DENSITY

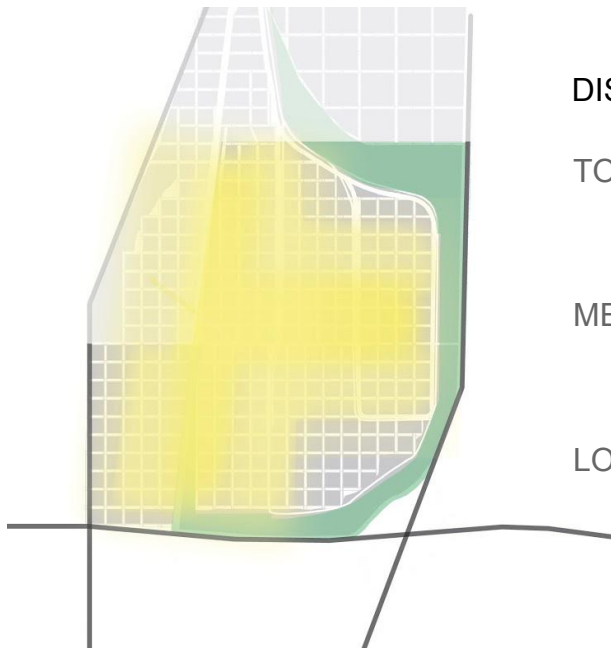
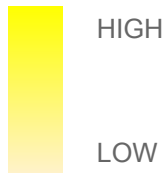

## DISTRIBUTION

TOD/ HIGH DENSITY = 40% at 150upa

MEDIUM-DENSITY = 50% at 80upa

LOW-DENSITY = 10% 45upa

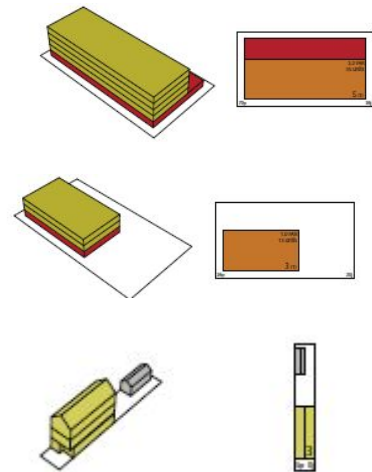

H

## A NEW STANDARD IN MIXED-USE RESIDENTIAL EMPHASIZING LIVE-WORK



Vauban, Freiburg



2110 Bay Street L.A. Mixed-use



Vastra Hamnen, Sweden. Carbon Neutral



Greenwich Millennium Village,



H

# HIGH DENSITY TRANSIT ORIENTED DEVELOPMENT

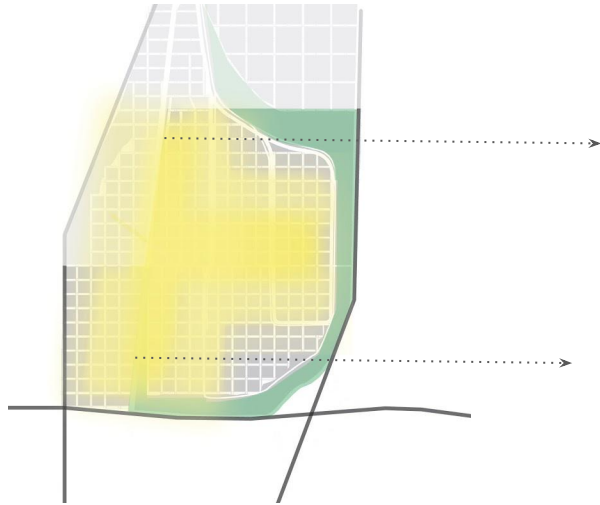

Brentwood TOD, Vancouver

H

# HIGH DENSITY RESIDENTIAL WITH COMMERCIAL AND INDUSTRIAL OPPORTUNITIES

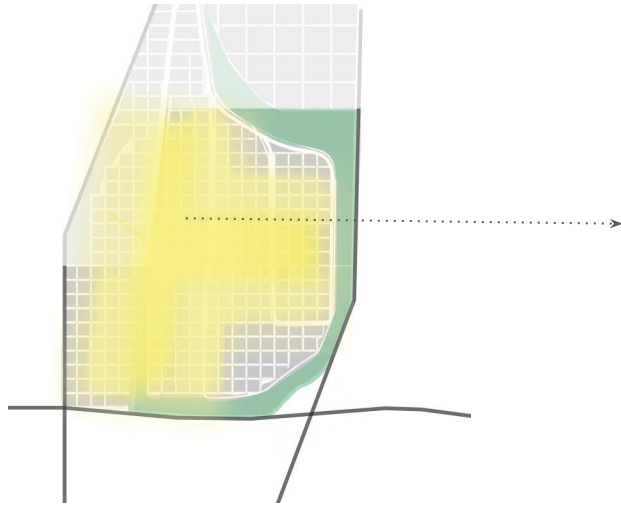

Hubei, China



H

MEDIUM DENSITY MIXED-USE INTEGRATED WITH REPURPOSED INDUSTRIAL

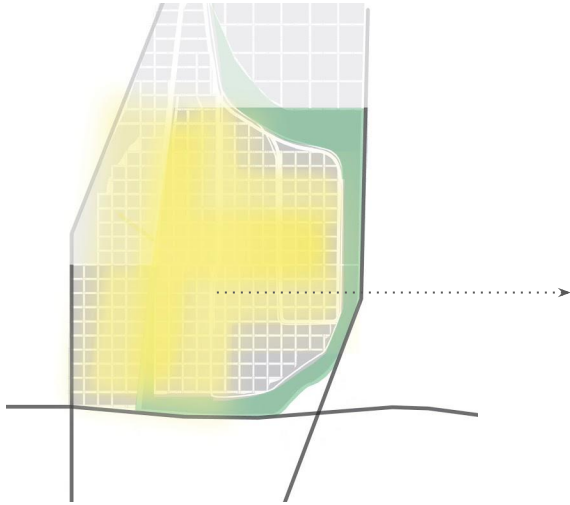

OCT Xi'an International Center

H

LOWER DENSITY RESIDENTIAL ALONG PERIPHERY TO INTEGRATE WITH CONTEXT

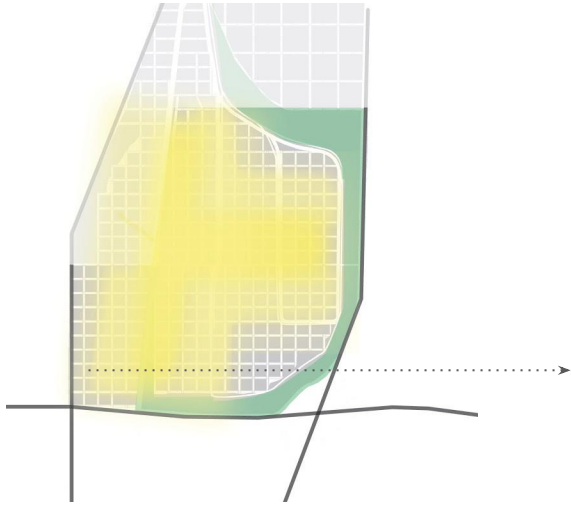

ReGen Village



H

ALL RESIDENCES SEAMLESSLY INTEGRATED WITH AND SERVED BY TRANSIT

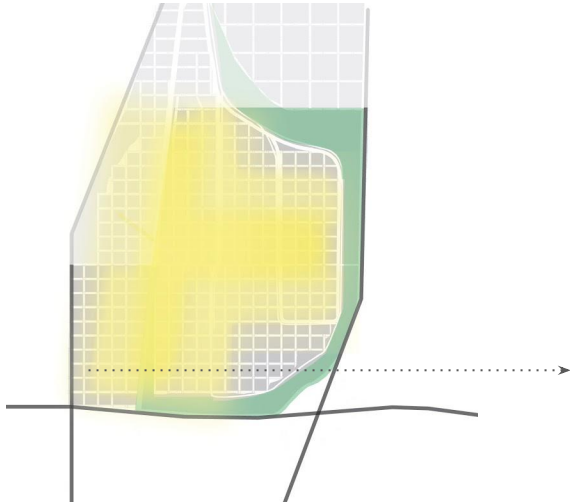

Charlotte Transit, Carolina

F



F

FOOD DEMAND

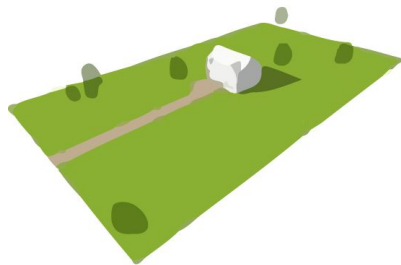

**1** acre  
feeds



**1** person  
for



**1** year

with minimal

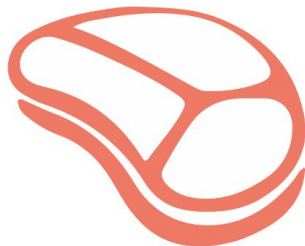

F

# VERTICAL FARMING



**190**  
times as productive  
per acre

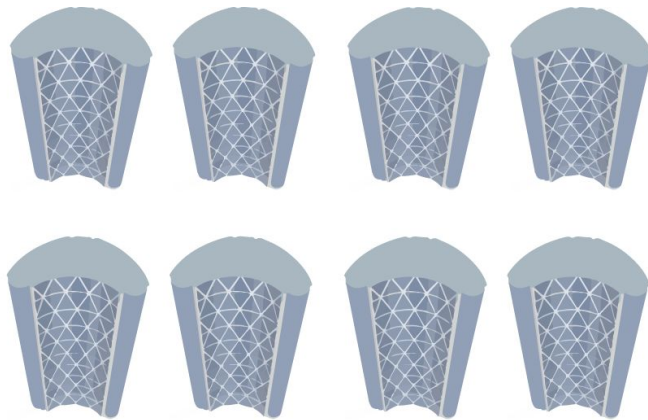

AeroFarms, Newark New Jersey



F

AGRISCAPING: a new public realm



F

GREEN ROOFS: energy efficient, productive corridors

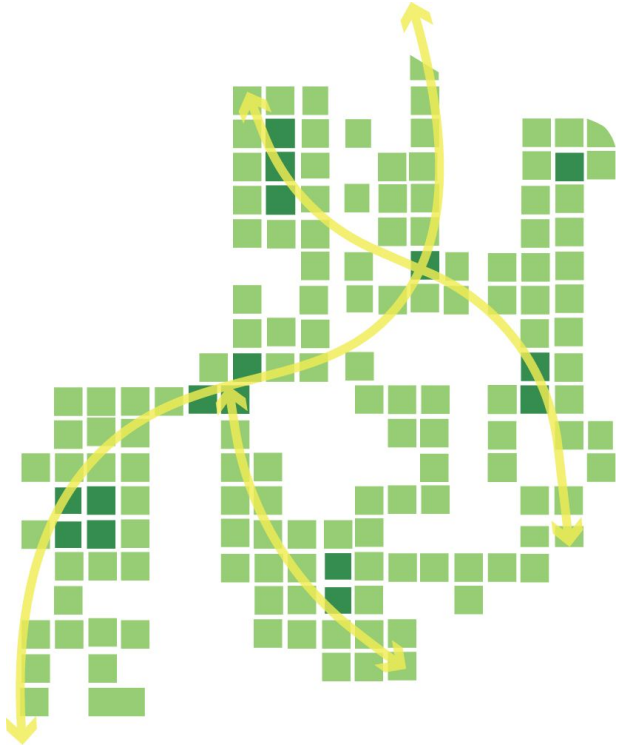



F

MANCHESTER: a productive district

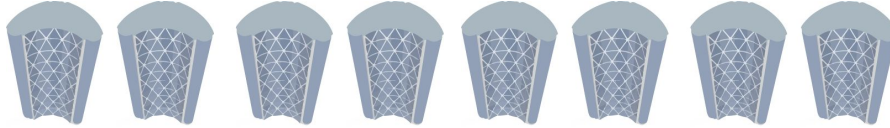

**16** million sq.ft

Vertical Farming

---

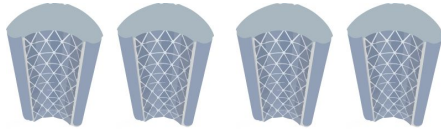

**8** million sq.ft

Green Roofs

---

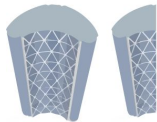
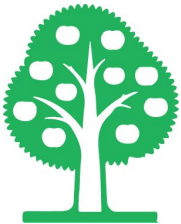

**2.85** million sq.ft

Agriscaping

---

E

## Calgary Skyline 2024

*“The signatory WECP cities commit that their Municipal Governments will be leaders and catalysts for change by taking their municipal government activities and approving of cial policies and plans to reduce these emissions by a minimum of 20% by 2020 and a minimum of 80% from the baseline by 2050 using 2005 as the baseline. The signatory WECP cities will establish a mechanism to report progress.”*

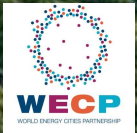

Calgary



# Is Calgary on Track?

## GHG Emissions Under the Baseline Scenario

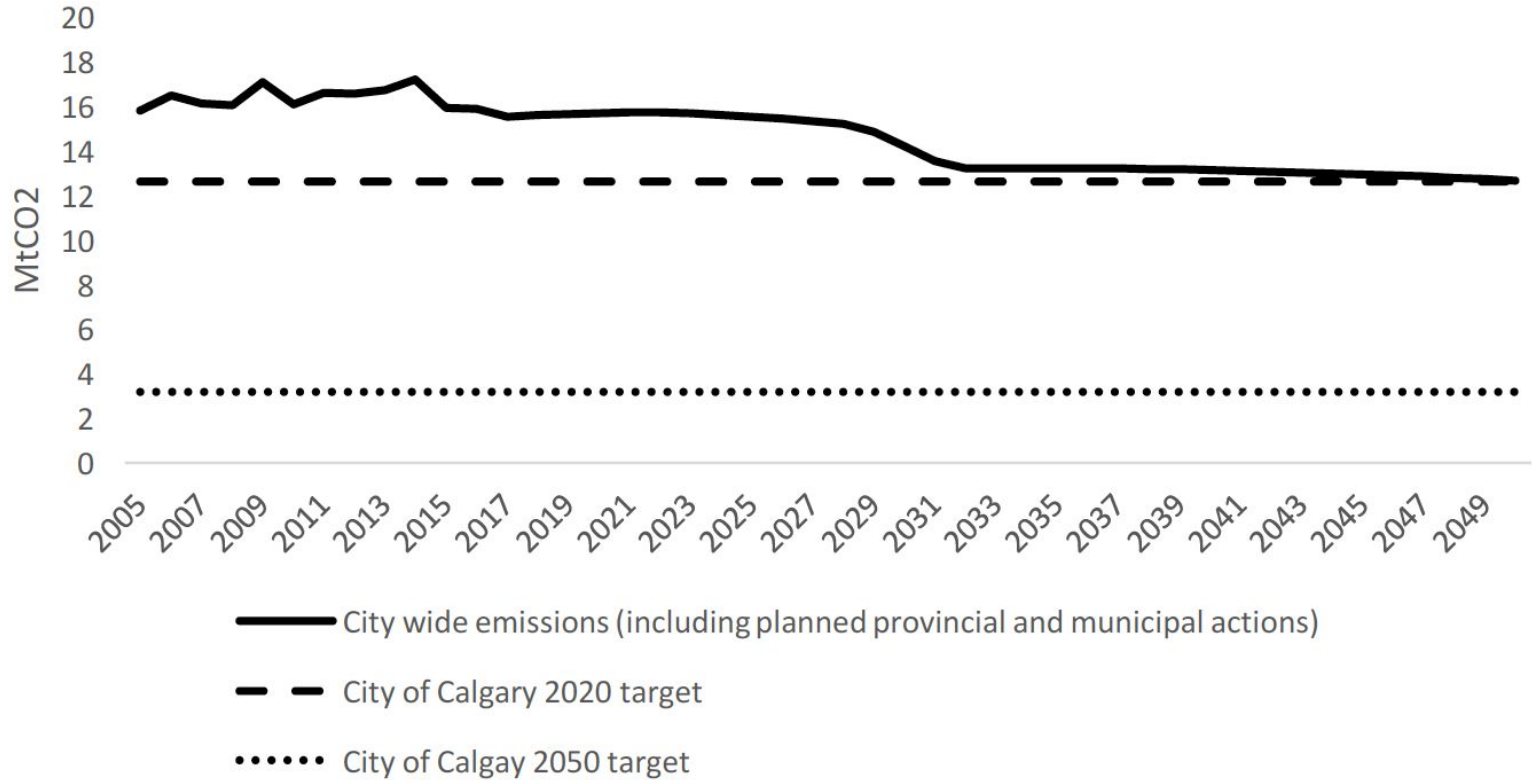

## 2017: Sources of Emissions

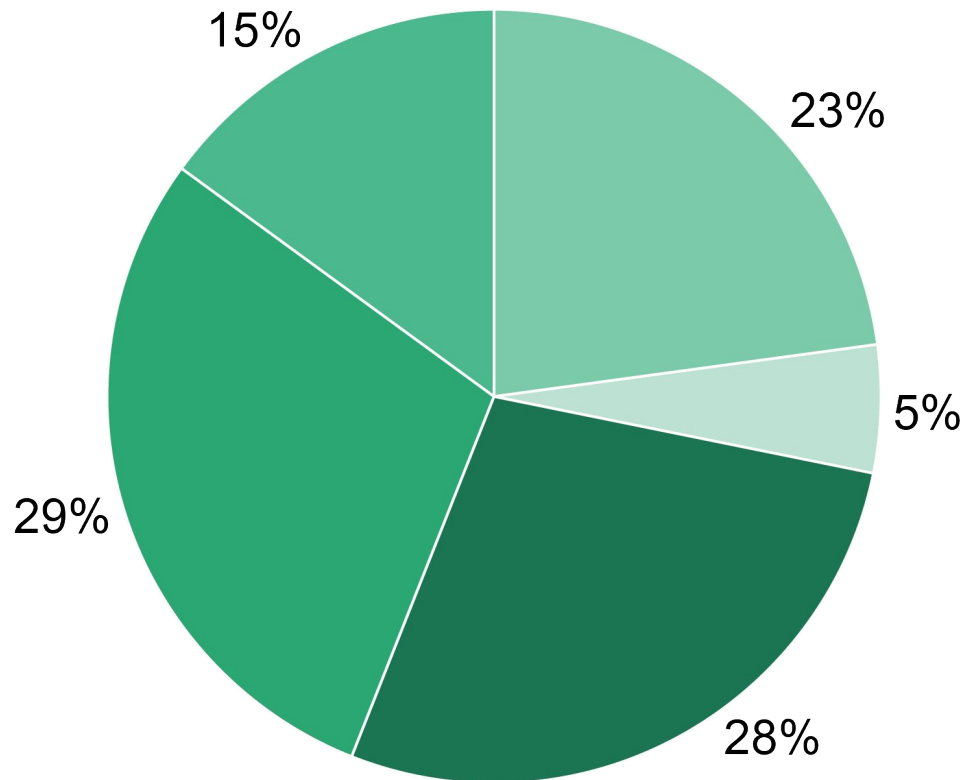

Commercial

Residential

Industry

Transportation

Waste

E

## Passive Energy Solutions

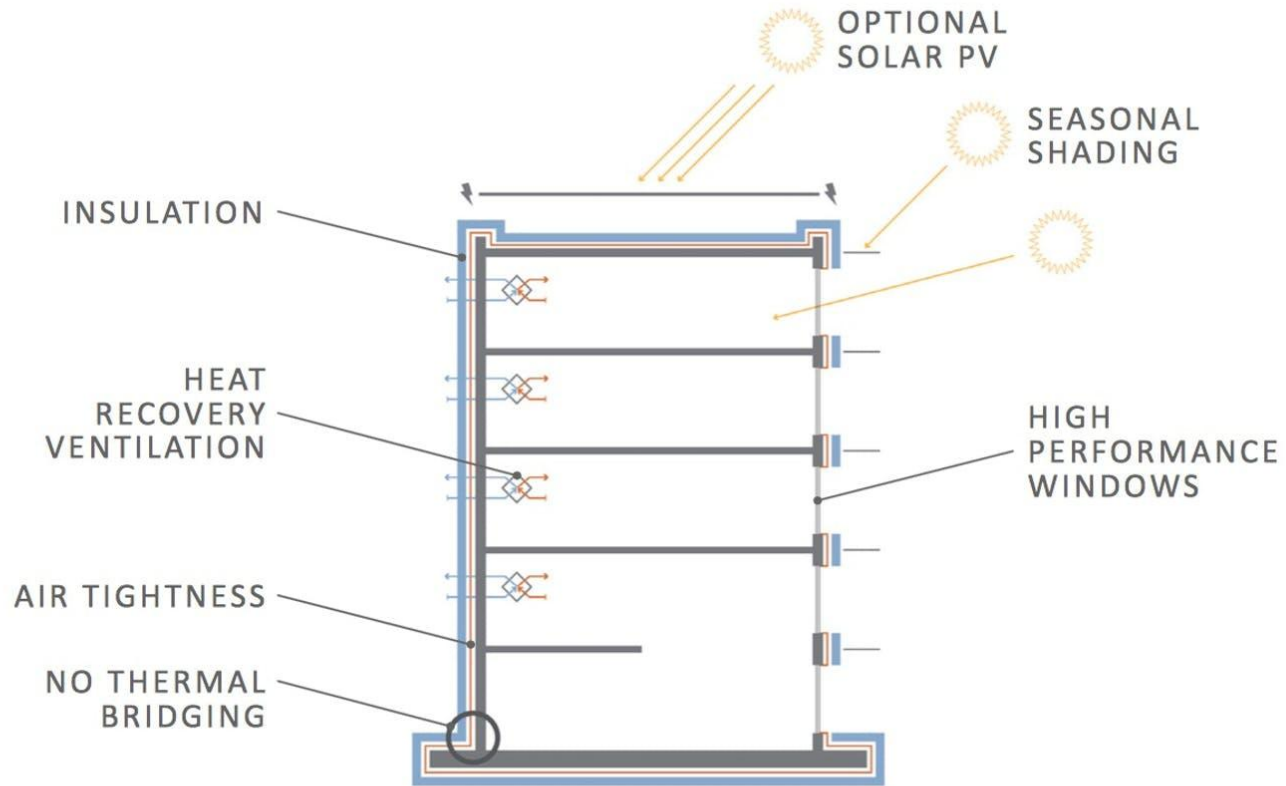

# Passive Energy Solutions

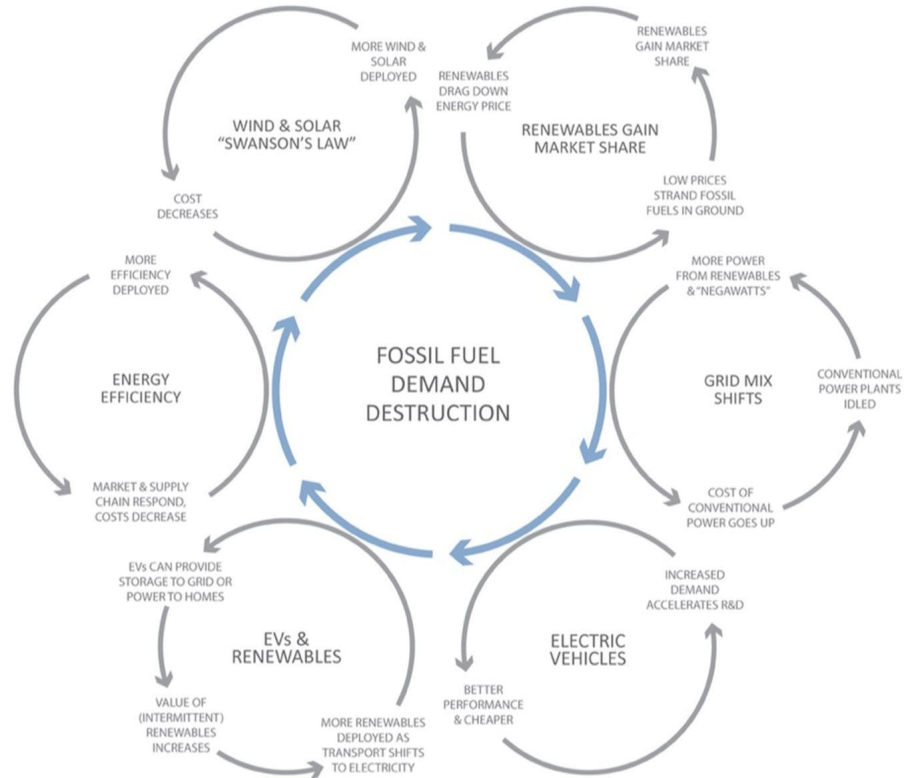

E

## Perkins & Will: passive + photovoltaic facade



## Wind Power



McBride Lake Wind Farm, Alberta

**Technology:**

114 Vestas V47 turbines

**Facility Capacity:**

75 MW

**Produces:**

235, 000 MWh/year

**Electrical Supply:**

32, 500 homes

**C02 Emission Reduction:**

164, 500 T



## Solar Thermal District Heating

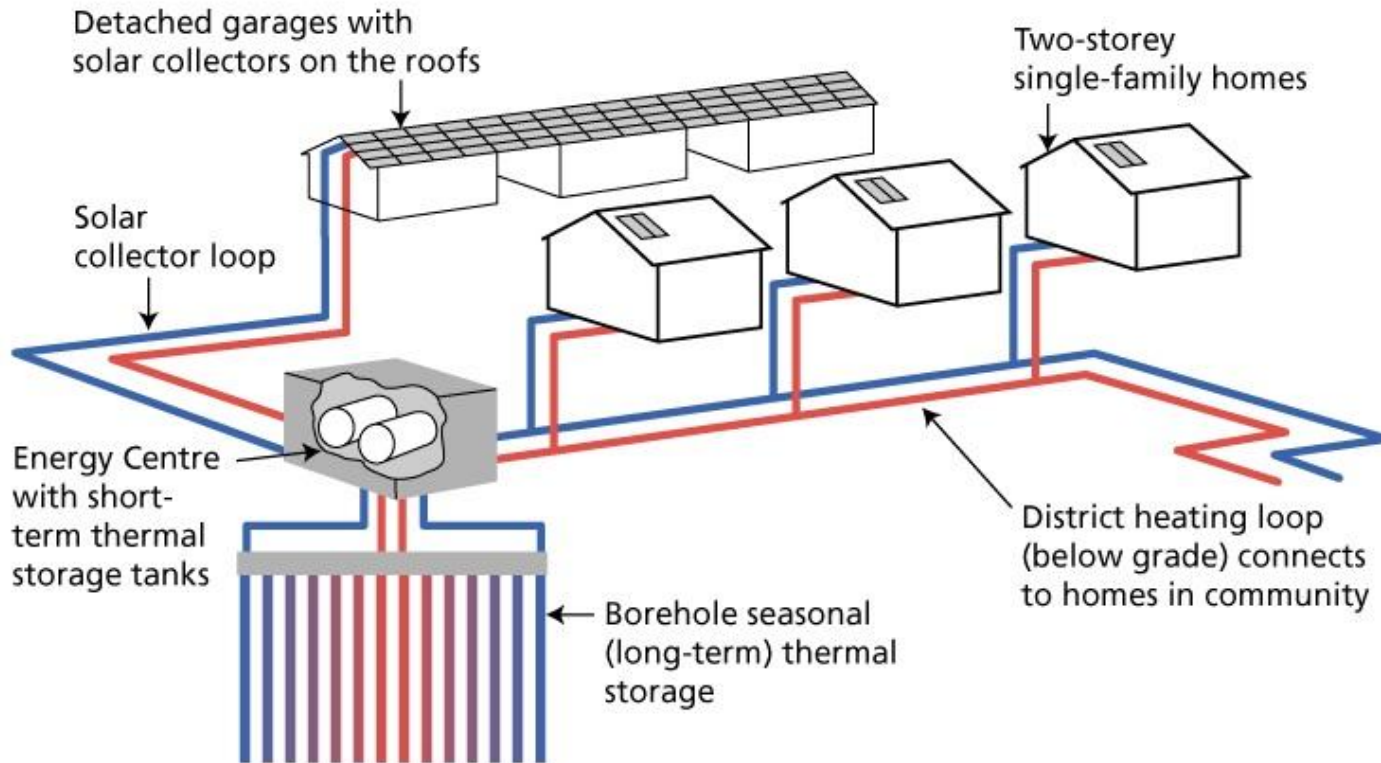

E

## Solar Thermal District Heating

**Technology:**

800 solar thermal collectors

Borehole Thermal Energy Storage (BTES)

**Facility Capacity:**

75 MW

**Supply:**

52 homes

Drake Landing, Okotoks, Alberta





E

## Solar Thermal District Heating

### Technology:

12, 436 solar thermal collectors

### Collector Area:

156, 694 m<sup>2</sup>



Silkeborg, Denmark

Vojens, Denmark



### Number of Consumers:

90, 000

### Annual Demand Covered:

20%

E

## Onsite: Solar Thermal District Heating

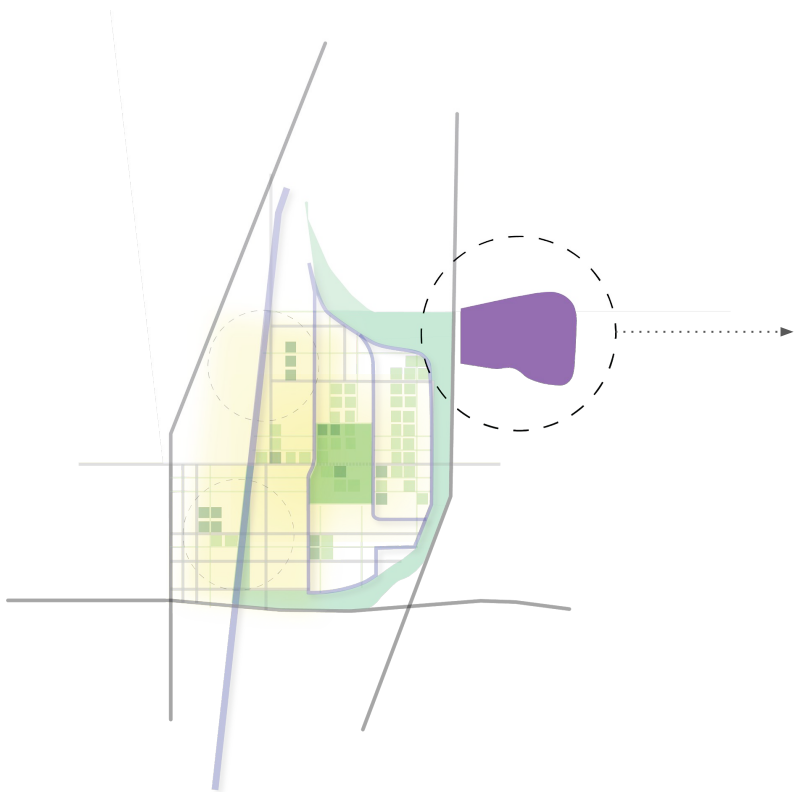



Complete List of Image Sources Found in Presentation Notes